

PFX36
PALLET FORK
MANUAL

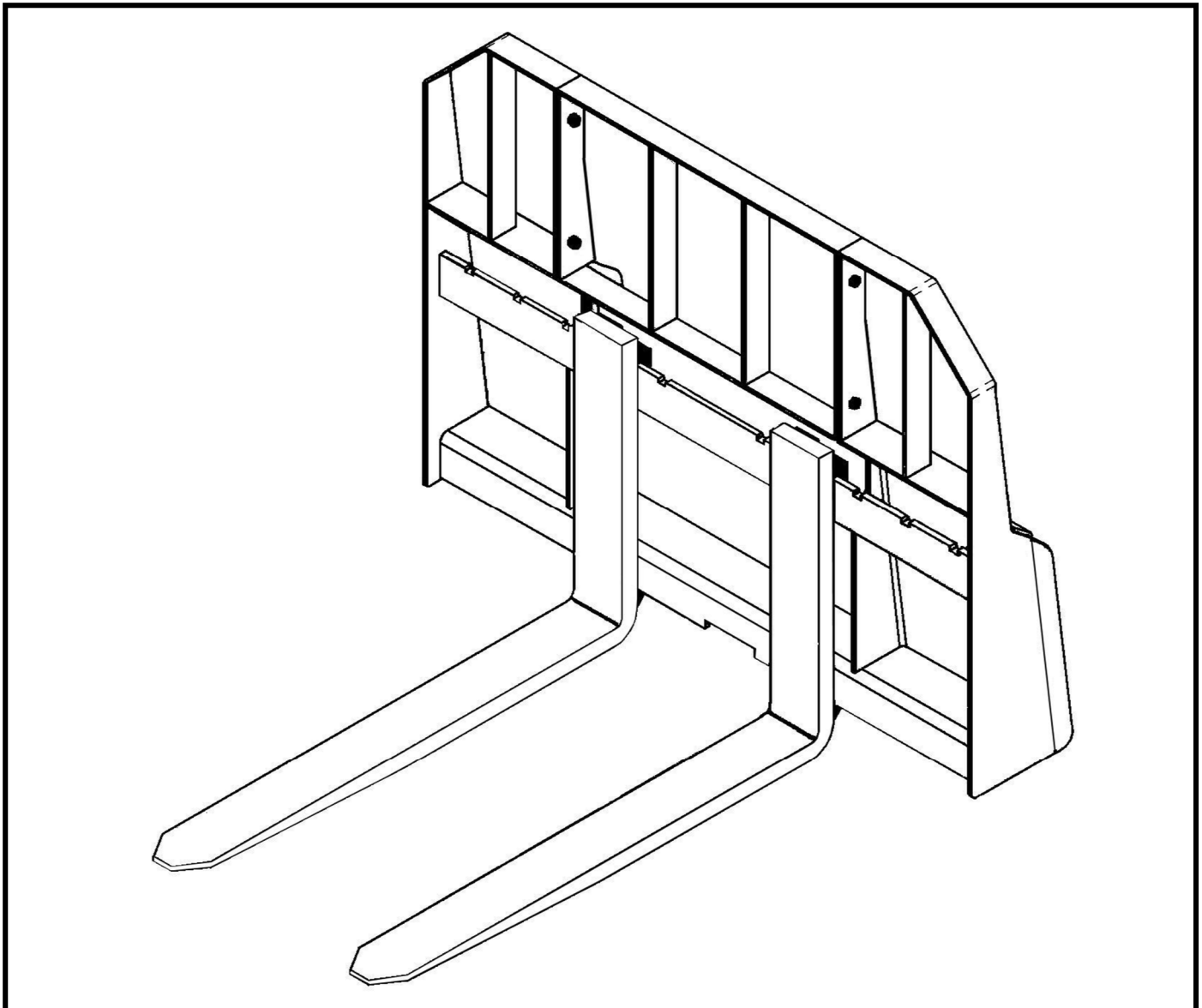

TO THE PURCHASER

This manual contains valuable information about your new Summit Tractor PFX36 pallet fork. It has been carefully prepared to give you helpful suggestions for operating, adjusting, servicing and ordering repair parts.

Keep this manual in a convenient place for quick and easy reference. Study it carefully. You have purchased a dependable and sturdy pallet fork, but only by proper care and operation can you expect to receive the service and long life designed and built into the product.

Sometime in the future your pallet fork may need new parts to replace those that are worn. If so, go to your dealer and provide him with the model and part number.

Customer Information

Name _____

Purchased From _____

Date Purchased _____

Model No. _____

It is the purchaser and/or operator's responsibility to....

I Read and understand the information contained in this manual.

I Operate, lubricate, assemble and maintain the equipment in accordance with all instructions and safety procedures in this manual.

I Inspect the equipment and replace or repair any parts that are damaged or worn which under continued operation would cause damage, wear to other parts, or cause a safety hazard.

I Return the equipment or parts to the authorized Summit Tractor dealer, from where it was purchased, for service or replacement of defective parts that are covered by warranty. (The Summit Tractor Factory or an Authorized Summit Tractor Dealer may inspect equipment or parts before warranty claims are honored.)

CONTENTS

ITEM	PAGE
Specifications	6
Safety	7
Safety Training	9
Preparation & Operational Safety.....	10
Safety Decals	12
Assembly.....	14
Adjust Forks, Before Operation & Transport	15
Maintenance & Operating Guides	16
Storage & Attaching.....	17
Replacement Parts.....	18
Warranty	19

SPECIFICATIONS

MODEL	PFX36
FORK LENGTH	36"
FRAME WIDTH	46-1/2"
FRAME HEIGHT	34"
HITCH TYPE	UNIVERSAL SKID STEER QUICK ATTACH
FRAME MATERIAL	A572 GRADE 50 STEEL
FRAME	REMOVABLE GUARD FOR WALK THRU APPLICATION
FORKS	MANUAL ADJUSTABLE CLASS II FORKS
TOTAL WT. CAPACITY	2,000 LBS.
APPROX. UNIT WEIGHT	292 LBS.

SAFETY

READ AND FOLLOW THE INSTRUCTIONS IN THIS MANUAL AND ESPECIALLY IN THE SAFETY SECTION. FAILURE TO DO SO CAN RESULT IN SERIOUS INJURY OR DEATH.

TAKE NOTE! THIS SAFETY ALERT SYMBOL FOUND THROUGHOUT THIS MANUAL IS USED TO CALL YOUR ATTENTION TO INSTRUCTIONS INVOLVING YOUR PERSONAL SAFETY AND THE SAFETY OF OTHERS.



THIS SYMBOL MEANS
ATTENTION!
BECOME ALERT!
YOUR SAFETY IS INVOLVED

SIGNAL WORDS:

The signal words **DANGER**, **WARNING** and **CAUTION** are used with the safety messages in this manual and with each safety signs. They are defined as follows:

DANGER: Indicates an immediate hazardous situation that, if not avoided, could result in serious injury or death. This signal word is to be limited to the most extreme situations typically for machine components that, for functional purposes, cannot be guarded.

WARNING: Indicates a potentially hazardous situation that, if not avoided, could result in serious injury or death, and includes hazards that are exposed when guards are removed. It may also be used to alert against unsafe practices.

CAUTION: Indicates a potentially hazardous situation that, if not avoided, may result in minor or moderate injury. It may also be used to alert against unsafe practice.

If you have any questions not answered in this manual or require additional copies or the manual is damaged, please contact your dealer or Summit Tractor LLC 3379 Peachtree Road NE Suite 555 Atlanta, GA 30326 (678) 916-6555.

EQUIPMENT SAFETY GUIDELINES



- I Safety of the operator and bystanders is one of the main concerns in designing and developing a pallet fork. However, every year accidents occur which could have been avoided by a few seconds of thought and a more careful approach to handling equipment. You, the operator, can avoid many accidents by observing the following precautions and insist those working with you, or for you, follow them.
- I In order to provide a better view, certain photographs or illustrations in this manual may show an assembly with a safety shield removed. However, equipment should never be operated in this condition. Keep all shields in place. If shield removal becomes necessary for repairs, replace the shield prior to use.
- I Replace any safety sign that is not readable or is missing. Copies of such safety signs are shown in this manual.
- I Never use alcoholic beverages or drugs that can hinder alertness or coordination while operating this equipment. Consult your doctor about operating this machine while taking prescription medications.
- I **Under no circumstances should children under the age of 18 be allowed to work with this equipment. Do not allow persons to operate or assemble this unit until they have read this manual and have developed a thorough understanding of the safety precautions and of how it works.** Review the safety instructions with all users annually.
- I This equipment is dangerous to children and persons unfamiliar with its operation. The operator should be a responsible, properly trained and physically able person familiar with farm machinery and trained in this equipment's operations. If the elderly are assisting with farm work, their physical limitations need to be recognized and accommodated.
- I Use a tractor equipped with a Roll Over Protective System and seat belts. (ROPS)
- I Never exceed the limits of a piece of machinery. If its ability to do a job, or to do so safely, is in question- **DON'T TRY IT.**
- I Do not modify the equipment in any way. Unauthorized modification could result in serious injury or death and may impair the function and life of the equipment.
- I In addition to the design and the confirmation of this implement, including safety signs and safety equipment, hazard control and accident prevention are dependent upon the awareness, concern, prudence, and proper training of personnel involved in the operation, transport, maintenance, and storage of the machine. Refer also to safety messages and operation instruction in each of the appropriate sections of the tractor or skid steer and pallet fork manuals. Pay close attention to the safety signs affixed to the tractor or skid steer and the pallet fork.

SAFETY TRAINING



- I Safety is a primary concern in the design and manufacture of our product. Unfortunately, our efforts to provide safe equipment can be wiped out by a single careless act of an operator or bystander.
- I In addition to the design and configuration of equipment, hazard control and accident prevention are dependent upon the awareness, concern, prudence and proper training of personnel involved in the operation, transport, maintenance and storage of this equipment.
- I It has been said, “The best safety device is an informed, careful operator.” We ask you to be that kind of operator. It is the operator’s responsibility to read and understand all safety and operating instructions in the manual and to follow them. Accidents can be avoided.
- I Working with unfamiliar equipment can lead to careless injuries. Read this manual, and the manual for your tractor or skid steer, before assembly or operating, to acquaint yourself with the machines. If this machine is used by any person other than you, or is loaned or rented, it is the pallet fork owner’s responsibility to make certain that owner’s manual be available to the operator prior to operating and that the operator:
 - 1- Reads and understands the operator’s manuals.
 - 2- Is instructed in safe and proper use.
- I Know your controls and how to stop tractor or skid steer, engine, and the pallet fork quickly in an emergency. Read this manual and the one provided with your tractor or skid steer.
- I Train all new personnel and review instructions frequently with existing workers. Be certain only a properly trained and physically able person will operate the machinery. A person who has not read and understood all operating and safety instructions is not qualified to operate the machine. An untrained operator exposes himself and bystanders to possible serious injury or death. If the elderly are assisting with farm work, their physical limitations need to be recognized and accommodated.

PREPARATION



- Always wear close fitting clothing and personal protection equipment called for by the job conditions. These items may include a hard hat, safety glasses, goggles or face shield, hearing protection and safety boots. DO NOT wear loose clothing, jewelry or any other items that may be entangled in moving parts. Tie up long hair.
- Ensure equipment is properly mounted, adjusted and in good operating condition.
- Tighten all bolts and nuts and check that all cotter pins are installed securely to ensure equipment is properly assembled before operating.
- Tractor must be equipped with an approved Roll-Over-Protective System (ROPS). Keep seat belt securely fastened. Falling off the tractor can result in serious injury or even death. Keep foldable ROPS systems in “locked up” position at all times.
- A minimum 20% of the combined tractor and equipment weight must be on the tractors front wheels with the equipment in transport position. Without this weight, tractor could tip over causing personal injury or death. See your tractors operators manual for information regarding adding weights.
- Remove accumulated debris from this equipment, tractor or skid steer, and engine to avoid fire hazard.
- Ensure all safety decals are installed. Replace if damaged.

OPERATIONAL SAFETY



- Operate only in daylight or good artificial light.
- Always comply with all state and local lighting and marking requirements.
- No riders on equipment.
- Always sit in tractor or skid steer seat with seat belt fastened when operating controls or starting engine. Place transmission in park or neutral, engage brake and ensure all other controls are disengaged before starting tractor or skid steer engine.
- Look down and to the rear and make sure area is clear before operating in reverse.
- Do not operate on steep slopes.
- Do not stop, start or change directions suddenly on slopes.
- Watch for hidden hazards on the terrain during operation.
- Stop implement and tractor or skid steer immediately upon striking an obstruction. Turn engine off, remove key, inspect and repair any damage before resuming operation.

OPERATIONAL SAFETY *continued...*



- I When performing any service or maintenance, disengage power to implement. Lower all raised components to the ground. Operate valve levers to relieve any hydraulic pressure. Shut off the engine, set the parking brakes and remove the ignition keys before dismounting tractor or skid steer.
- I Keep all persons away from operator control area while performing adjustments, service or maintenance.
- I Always stop the tractor or skid steer, set brake, shut off the tractor or skid steer engine, remove the ignition key, lower implement to the ground and allow everything to come to a complete stop before dismounting tractor or skid steer. Never leave equipment unattended with the tractor or skid steer running.
- I Never place hands or feet close to pallet fork with tractor or skid steer engine running or before you are sure all motion has stopped. Stay clear of all moving parts.
- I Do not reach or place any part of your body close to equipment until it is blocked securely.
- I Do not allow riders on the tractor or skid steer at anytime. There is no safe place for any riders.
- I Do not operate unless all personnel, livestock, and pets are several feet away to prevent injury.
- I The rotating parts of this machine have been designed and tested for rugged use. However, they could fail upon impact with heavy, solid objects such as steel guardrails and concrete abutment. Such impact could cause the broken objects to be thrown outward. To reduce the possibility of property damage, serious injury, or even death, never allow the pallet fork to contact such obstacles.
- I Stop the pallet fork and tractor or skid steer immediately upon striking an obstruction. Turn engine off, remove key, inspect and repair any damage before resuming operation.
- I Stay alert for uneven terrain, rocks, and roots and other hidden hazards. Keep away from drop-offs and hazards that could cause roll over. Use extreme care and maintain minimum ground speed when transporting or operating on hillsides, over rough ground and when operating close to ditches or fences. Be careful and slow down when turning sharp corners and changing direction on slopes. Do not start or stop suddenly on slopes. Avoid operation on steep slopes. In extremely uneven terrain, rear wheels weights, front tractor weight, and/or tire ballast should be used to improve stability.
- I Always check tractor or skid steer manual for proper use on slopes.

OPERATIONAL SAFETY *continued...*

- I When using a piece of equipment, a minimum 20% of tractor and equipment weight must be on tractor front wheels. Without this weight, tractor could tip over, causing personal injury or death. The weight may be attained with a front-end loader, front wheel weights, ballast in the tires or front tractor weights. When attaining a minimum 20% of tractor and equipment weight on the front wheels, you must not exceed the ROPS weight certification. Weigh the tractor and equipment. **Do not guess or estimate!**

SAFETY DECALS

Make sure all safety decals are clean and legible.

Replace worn or missing decals.

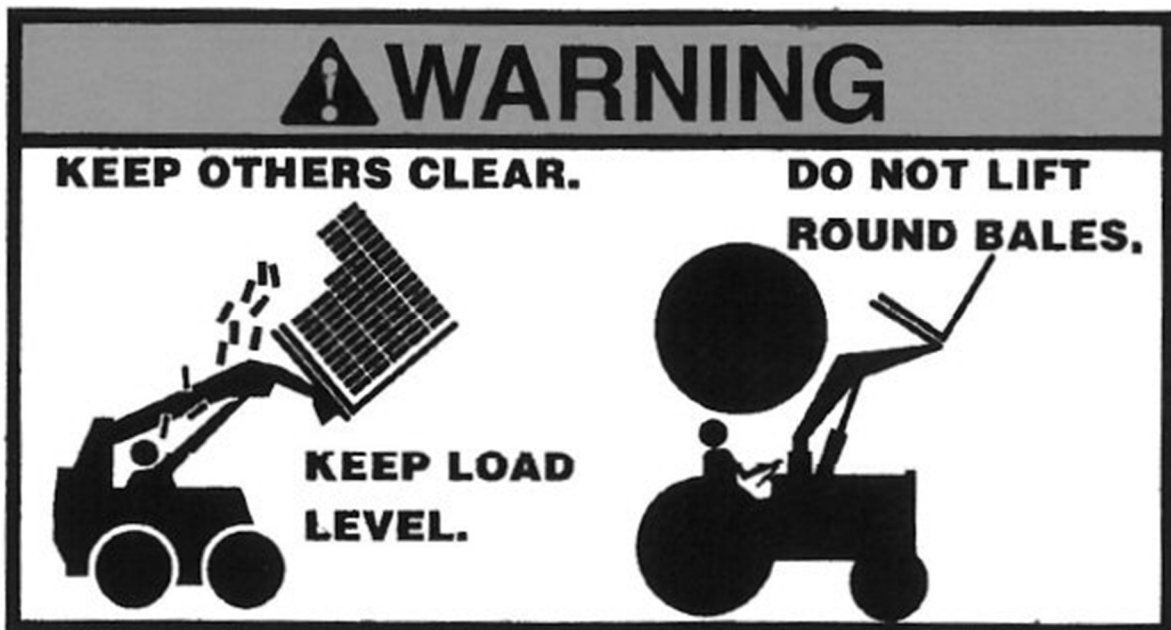



**2000 LB
CAPACITY**

ASSEMBLY

Fork Installation

CAUTION



To avoid minor or moderate injury: A pinching hazard exists when installing forks. Do not place hands or fingers between carrying bars and forks.

- 1.) Raise handle of fork locking pin (#1) straight up.
- 2.) Center upper end of fork (#2) on upper carrying bar (#3). Make sure retaining hook (A) is caught behind upper carrying bar (#3) and retaining hook (B) fits in notch opening in lower carrying bar (#4).
- 3.) Slide fork to the right by pushing on the fork near carrying bars (#3 & #4) until locking pin (#1) is positioned over one of the pin notches.
- 4.) Lower locking pin handle (#1) to seat pin in the selected notch. Make sure locking pin is seated and retaining hooks (A & B) are secured behind the carrying bars.
- 5.) Repeat steps 1-4 for the second fork, but slide the second fork to the left.

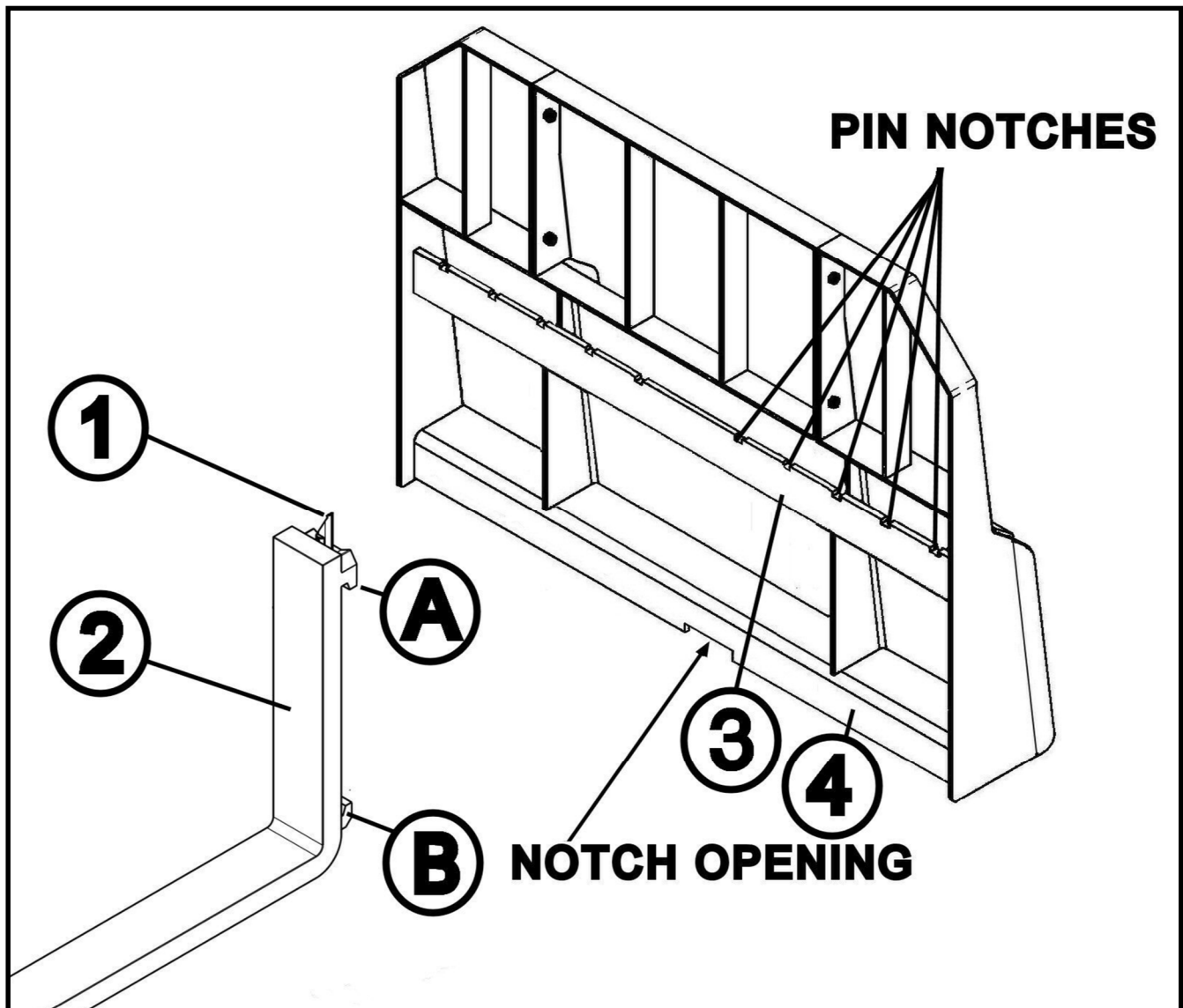

ADJUSTING FORK

SPACING

- 1.) Raise latch lever (1), and manually slide the fork to the desired position.
- 2.) Lower the lever and make sure the pin drops into locating notch (2).

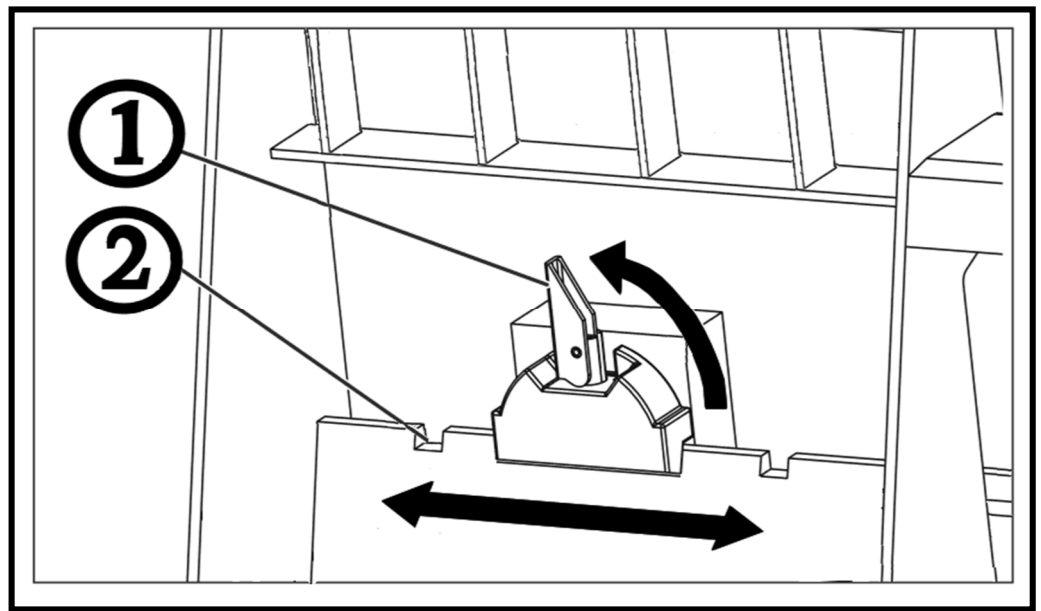

BEFORE OPERATION

- 1) Tighten all loose hardware. Replace any missing hardware. On new machines, all hardware must be rechecked after first few hours of operation.
- 2) Replace any bent or broken parts.
- 3) Refer to your Tractor's Owner's Manual for recommended adjustments and weight distribution.
- 4) Check pallet fork for signs of wear or damage. Replace if necessary. SEE MAINTENANCE.
- 5) Read the SAFETY section of this manual to be sure of all precautions.

TRANSPORTING

- 1) Use a Slow - Moving - Vehicle (SMV) emblem and proper lighting on the tractor when transporting the pallet fork.
- 2) Always comply with all state and local lighting and marking requirements.
- 3) Do not drive the tractor and pallet fork over 20 MPH (30 KPH) on the best surface conditions. Reduce speed when going up or down hills and when approaching ditches or corners.
- 4) Check condition of hitch pins and bolts before transporting.
- 5) Raise pallet fork to highest position for transport.
- 6) Travel at a speed safe for terrain and other conditions.
- 7) Keep your pallet fork in proper working condition. Unauthorized modifications to the pallet fork may impair the function, affect pallet fork life, and put you at risk. Do not add weight to pallet fork. Additional weight could cause frame to fail resulting in loss of control of pallet fork/tractor during transport.
- 8) Check local laws governing transport of farm equipment on public roads.
- 9) Use caution and be aware of oncoming traffic and roadside obstructions.
- 10) DO NOT transport on public roads at night.

MAINTENANCE

WARNING



To avoid serious injury or death:

- *Make sure controls are all in neutral position or park before starting the power machine.*
- *Perform scheduled maintenance. Check for loose hardware, missing parts, broken parts, structural cracks, and excessive wear. Make repairs before putting the implement back into service.*
- *Do not alter implement or replace parts on the implement with other brands. Other brands may not fit properly or meet OEM (Original Equipment Manufacturer) specifications. They can weaken the integrity and impair the safety, function, performance, and life of the implement. Replace parts only with genuine OEM parts.*

Proper servicing and adjustments are key to the long life of any implement. With careful inspection and routine maintenance, you can avoid costly downtime and repair.

1. After using your pallet fork for a few lifts, check forks to make sure they are still secured and check pallet fork to make sure it is still properly attached to the loader hitch.
2. Check forks to make sure they are not damaged, broken, or worn excessively. Repair or replace as needed.
3. Always remove any material that has become entangled in the forks before continuing to use them.
4. Replace any worn, damaged, or illegible safety labels by obtaining new labels from your Summit Tractor dealer.

OPERATING GUIDELINES

1. Adjust the spacing of the forks as wide as possible to increase load stability.
2. Before lifting make sure the forks are completely under the load and level. The fork length should be at least two-thirds of the load length.
3. Keep the weight of the load centered between the forks. If a load is heavy on one side, place the heaviest side closest to the skid steer.
4. Raise the forks to enter the pallet/load and keep the angle of the forks parallel with the ground.
5. Always keep the load or pallet as close to the skid steer as possible.
6. Make sure the weight of the load is centered between the forks.
7. Lift the load slightly to make sure it is stable. If the load appears unstable, lower and reposition the forks. Lift slowly and smoothly.

OPERATING GUIDELINES continued..

8. Raise the load to the minimum height required for the terrain.
9. Before moving a load, check all directions for pedestrians or other obstacles.
10. When moving a load; a) keep the forks level, b) accelerate and brake gradually, c) slow down before turning and avoid any obstacles, bumps or holes, 4) If possible travel straight up and down on grades, ramps, or inclines and avoid turning, 5) if the load is large and blocks your view, travel in reverse.
11. If the load starts to lean or move, lower it to the ground and reposition the forks.
12. Lower the load gently until the weight of the load is securely resting on the ground and the forks are free to be removed from the load.

STORAGE

- 1) Store on a level surface sheltered from the weather.
- 2) Lower equipment to the ground and sit on a flat surface.
- 3) Clean all debris from implement.
- 4) Keep playing children and bystanders away from storage area.



ATTACHING

WARNING

Be sure bystanders are clear. Do not stand between pallet fork and tractor or skid steer. Shut off tractor or skid steer and engage parking brake prior to dismounting.

CONNECTING

1. Lay the pallet forks on a flat surface, making sure the backing plate is facing opposite you.
2. Get in the skid steer or tractor and line up the machine with the backing plate of the pallet forks.
3. Once the backing plate is lined up, move the boom upwards which will allow the pallet forks backplate to connect to the skid steer.
4. Once the pallet forks are connected to the skid steer or tractor, you'll then need to connect the locking pins which are two levers on either side of the pallet forks (these locking pins will keep the pallet forks attached to the skid steer or tractor).
5. Once all these steps are completed, you're ready to take on your project.

DISCONNECTING

1. Start by first lowering the pallet forks onto a flat surface.
2. Lift up the two levers on either side of the pallet forks, releasing the locking pins. This will allow the pallet forks to be easily taken off the skid steer or tractor.
3. When all these steps have been completed, drive the tractor or skid steer out slowly to disconnect the pallet forks from the machine.

The steps above relate to most models of skid steers, tractors and pallet forks but depending on the size of your skid steer and the pallet fork's size, there may be a few more steps required.

PFX36 PARTS DIAGRAM

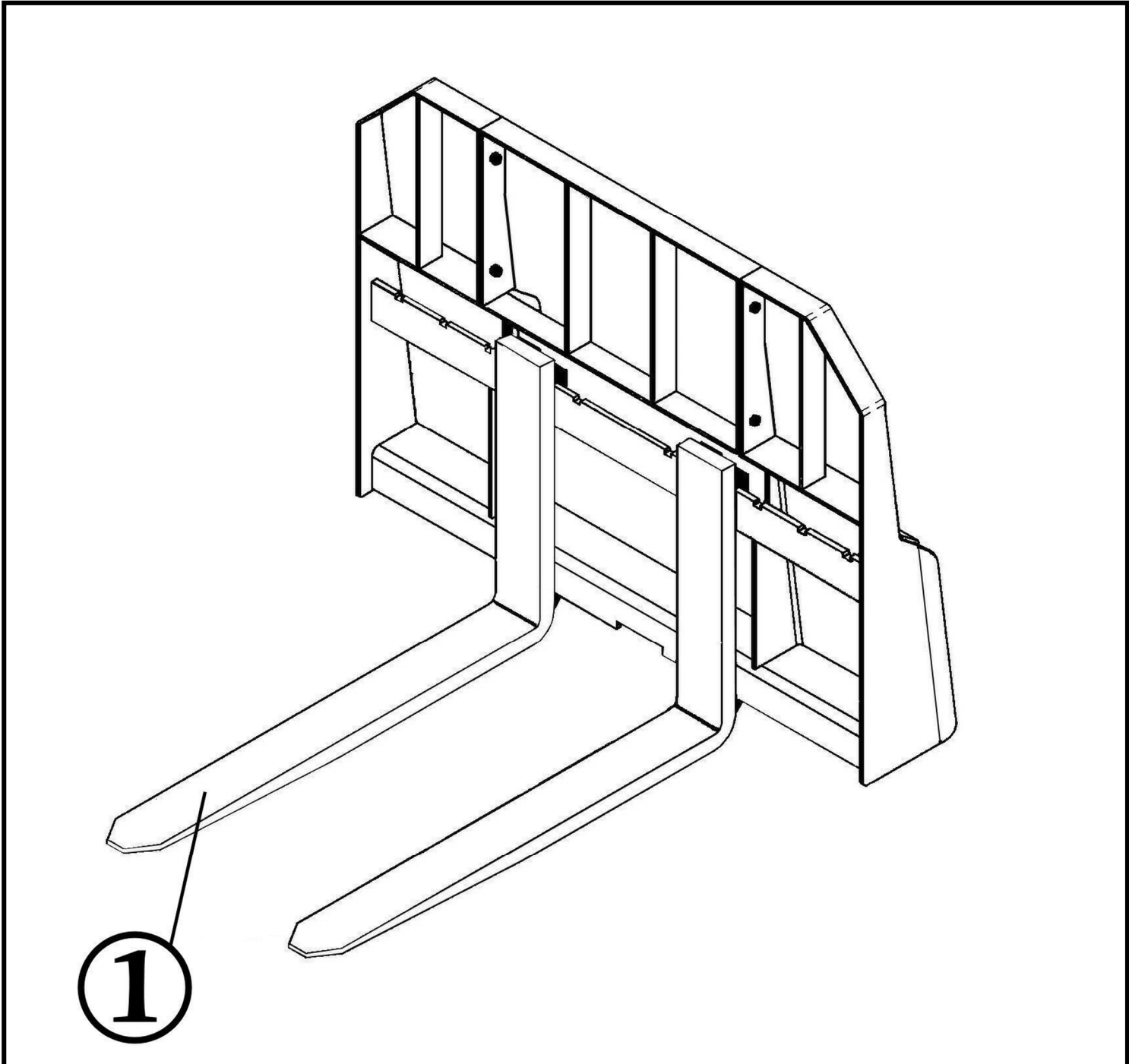

Ref. No.		Part #
	Model #	PFX36
1	Fork (Each)	147937



1. Limited Warranty.

Summit Tractors LLC, 3379 Peachtree Road NE Suite 555 Atlanta, GA 30326, warrants to the original retail purchaser ("Purchaser") that the product that is the subject of this sale is free from defects in material and workmanship at the time of sale.

Under this warranty, Summit Tractors will repair the defective product free of charge to the Purchaser, with either new or used and reconditioned replacement parts. All warranty service will be performed at service centers designated by Summit Tractors. If Summit Tractors is unable to repair the product to conform to the warranty after a reasonable number of attempts, Summit Tractors will provide, at its option, one of the following: (a) a replacement for the product or, (b) a full refund of the purchase price. Repair, replacement, or refunds are the Purchaser's EXCLUSIVE remedies against Summit Tractors under this limited warranty. Summit Tractors will not be liable for any special, incidental or consequential damages based upon breach or warranty, breach of contract, negligence, strict tort liability, or any other legal theory. Such damages include, but are not limited to, loss of profits, loss of savings or revenue, loss of use of the product or any associated equipment, cost of capital, cost of any substitute equipment, facilities or services, down time, the claims of third parties including customers, and injury to property. These limitations also apply, to the extent allowed by law, to personal injury.

The purchaser must notify the Seller in writing of any defect in material or workmanship within one (1) year following the date of purchase. If the equipment is used for commercial purposes, the Purchaser must notify the Seller in writing of any defect in material or workmanship within ninety (90) days following the date of purchase. In no event will Summit Tractors be liable under this warranty unless written notice is received by the Seller within one (1) year from the date of original retail sale.

2. Warranty of Title.

Summit Tractors warrants that it transfers a good title to the product free of any encumbrances, and free of the rightful claim of any third party for infringement of patent or copyright.

3. What is Not Covered by This Limited Warranty.

Summit Tractors will not be responsible for damage to or failure in the product which results from accident, misuse, abuse, neglect, installation of attachments not provided by Summit Tractors, modifications to the product, or damage caused by use of the product for purposes other than those for which it was designed.

4. No Other Warranties.

Unless modified in writing and signed by both parties, this agreement is understood to be the complete and exclusive agreement and warranty between Summit Tractors and Purchaser, superseding all prior agreements, oral and written, and all other communication between Summit Tractors and Purchaser related to the subject matter of this agreement.

THIS LIMITED WARRANTY IS IN LIEU OF ALL OTHER WARRANTIES, EXPRESS OR IMPLIED, INCLUDING, BUT NOT LIMITED TO, THE IMPLIED WARRANTY OF MERCHANTABILITY AND THE IMPLIED WARRANTY OF FITNESS FOR A PARTICULAR PURPOSE. No employee of Summit Tractors nor anyone else is authorized to make any warranty or representation in addition to or different from those made in this agreement.

5. Allocation of Risk.

This agreement allocates the risk of product failure between Summit Tractors and the Purchaser. This Allocation is recognized by both parties as reflected in the price of the goods. The Purchaser acknowledges that he or she has read this agreement, understands it, and is bound by its terms.